

# External Dimensions Units: mm

## (1) SGLGW-30

- Moving Coil: SGLGW-30A□□□C□ (With a connector by Tyco Electronics AMP K.K.)

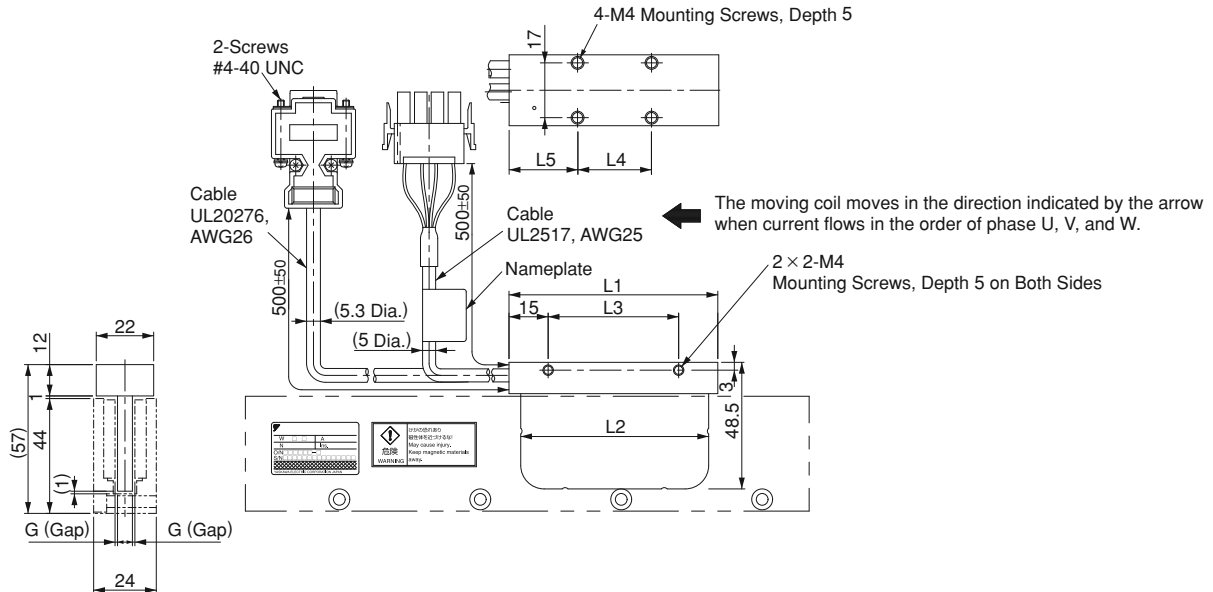

### Hall Sensor Connector Specifications

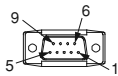

Pin Connector:  
17JE-23090-02 (D8C)  
by DDK Ltd.

The Mating Connector  
Socket Connector  
: 17JE-13090-02 (D8C)  
Stud : 17L-002C or  
17L-002C1

Pin No.	Signal
1	+5V (Power supply)
2	Phase U
3	Phase V
4	Phase W
5	0V (Power supply)
6	Not used
7	Not used
8	Not used
9	Not used

### Linear Servomotor Connector Specifications

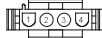

Plug : 350779-1  
Pin : 350924-1 or  
770672-1  
by Tyco Electronics AMP K.K.

The Mating Connector  
Cap : 350780-1  
Socket : 350925-1 or  
770673-1

Pin No.	Signal	Wire Color
1	Phase U	Red
2	Phase V	White
3	Phase W	Blue
4	FG	Green

### Hall Sensor Output Signals

When the moving coil moves in the direction indicated by the arrow in the figure, the relationship between the hall sensor output signals  $S_u$ ,  $S_v$ ,  $S_w$  and the inverse power of each motor phase  $V_u$ ,  $V_v$ ,  $V_w$  becomes as shown in the figure below.

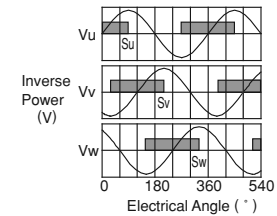

Moving Coil Model SGLGW-	L1	L2	L3	L4	L5	G (Gap)	Approx. Mass* kg
30A050C□	50	48	30	20	20	0.85	0.14
30A080C□	80	72	50	30	25	0.95	0.19

\*: The values indicate the mass of moving coil with a hall sensor unit.

**External Dimensions** Units: mm

- Moving Coil: SGLGW-30A□□□C□D (With a connector by Interconnectron GmbH)

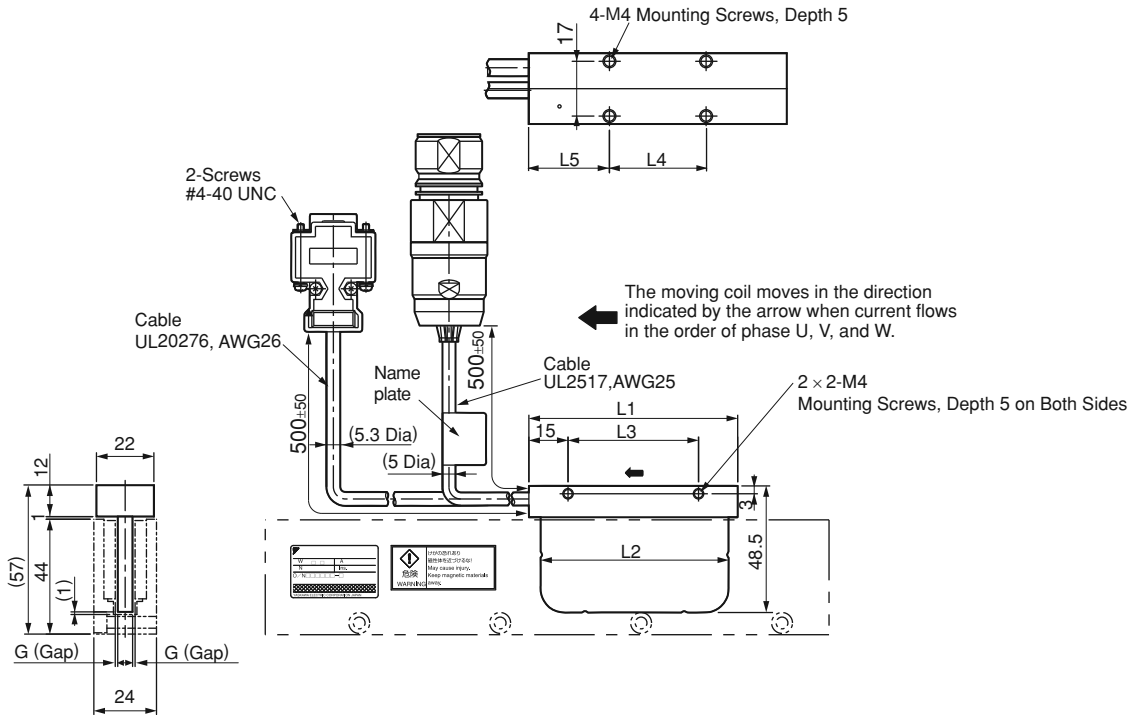

**Hall Sensor Connector Specifications**

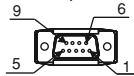

Pin Connector : 17JE-23090-02 (D8C) by DDK Ltd.

**The Mating Connector**

Socket Connector : 17JE-13090-02 (D8C)  
Stud : 17L-002C or 17L-002C1

Pin No.	Signal
1	+5V (Power supply)
2	Phase U
3	Phase V
4	Phase W
5	0V (Power supply)
6	Not used
7	Not used
8	Not used
9	Not used

**Linear Servomotor Connector Specifications**

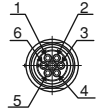

Extension: SROC06JM5CN169  
Pin : 021.423.1020  
by Interconnectron GmbH

**The Mating Connector**

Plug : SPUC06KFSDN236  
Socket: 020.030.1020

Pin No.	Signal	Wire Color
1	Phase U	Red
2	Phase V	White
3	Phase W	Blue
4	Not used	—
5	Not used	—
6	FG	Green

**Hall Sensor Output Signals**

When the moving coil moves in the direction indicated by the arrow in the figure, the relationship between the hall sensor output signals Su, Sv, Sw and the inverse power of each motor phase Vu, Vv, Vw becomes as shown in the figure below.

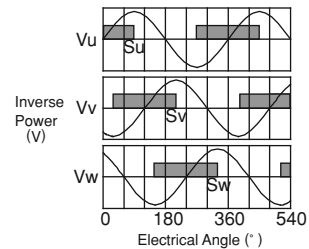

Moving Coil Model SGLGW-	L1	L2	L3	L4	L5	G (Gap)	Approx. Mass* kg
30A050C□D	50	48	30	20	20	0.85	0.14
30A080C□D	80	72	50	30	25	0.95	0.19

\*: The values indicate the mass of moving coil with a hall sensor unit.

External Dimensions Units: mm

● Magnetic Way: SGLGM-30□□□A

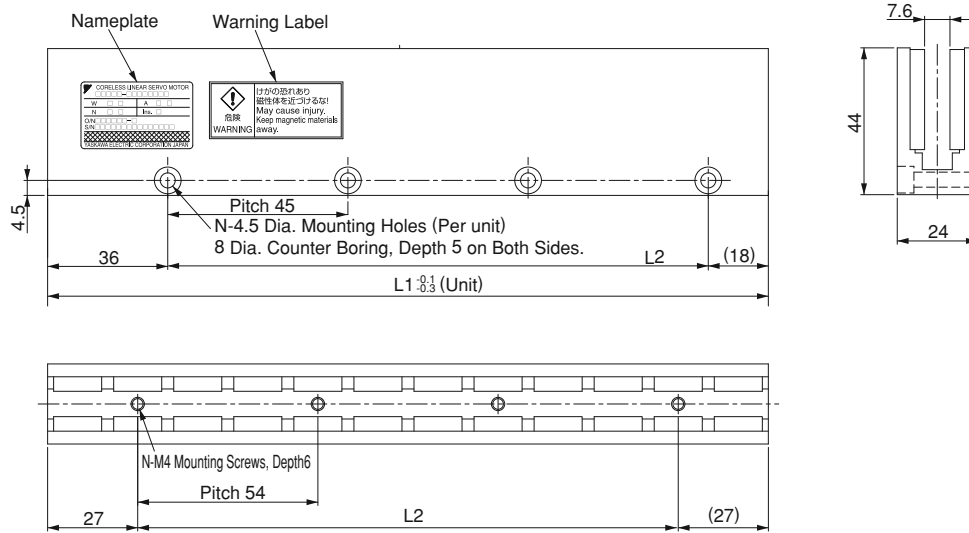

Magnetic Way Model SGLGM-	L1	L2	N	Approx. Mass kg
30108A	108	54	2	0.6
30216A	216	162	4	1.1
30432A	432	378	8	2.3

Note: If you have a pacemaker or any other electronic medical device, do not go near the magnetic way of the linear servomotor.

**External Dimensions** Units: mm

(2) SGLGW-40

- Moving Coil: SGLGW-40A□□□C□ (With a connector by Tyco Electronics AMP K.K.)

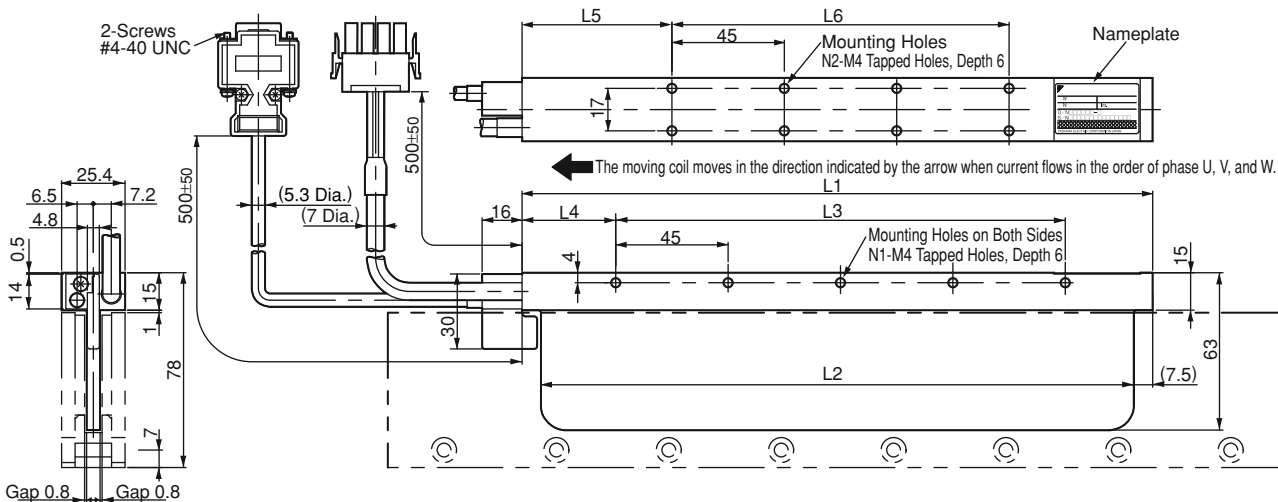

**Hall Sensor Connector Specifications**

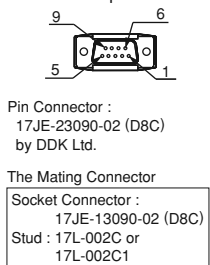

Pin No.	Signal
1	+5V (Power supply)
2	Phase U
3	Phase V
4	Phase W
5	0V (Power supply)
6	Not used
7	Not used
8	Not used
9	Not used

**Linear Servomotor Connector Specifications**

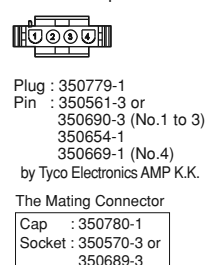

Pin No.	Signal	Wire Color
1	Phase U	Red
2	Phase V	White
3	Phase W	Blue
4	FG	Green

**Hall Sensor Output Signals**

When the moving coil moves in the direction indicated by the arrow in the figure, the relationship between the hall sensor output signals  $S_u$ ,  $S_v$ ,  $S_w$  and the inverse power of each motor phase  $V_u$ ,  $V_v$ ,  $V_w$  becomes as shown in the figure below.

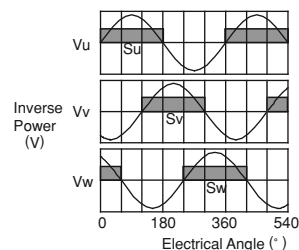

Moving Coil Model SGLGW-	L1	L2	L3	L4	L5	L6	N1	N2	Approx. Mass* kg
40A140C□	140	125	90	30	52.5	45	3	4	0.40
40A253C□	252.5	237.5	180	37.5	60	135	5	8	0.66
40A365C□	365	350	315	30	52.5	270	8	14	0.93

\*: The values indicate the mass of moving coil with a hall sensor unit.

## External Dimensions Units: mm

- Moving Coil: SGLGW-40A□□□C□D (With a connector by Interconnectron GmbH)

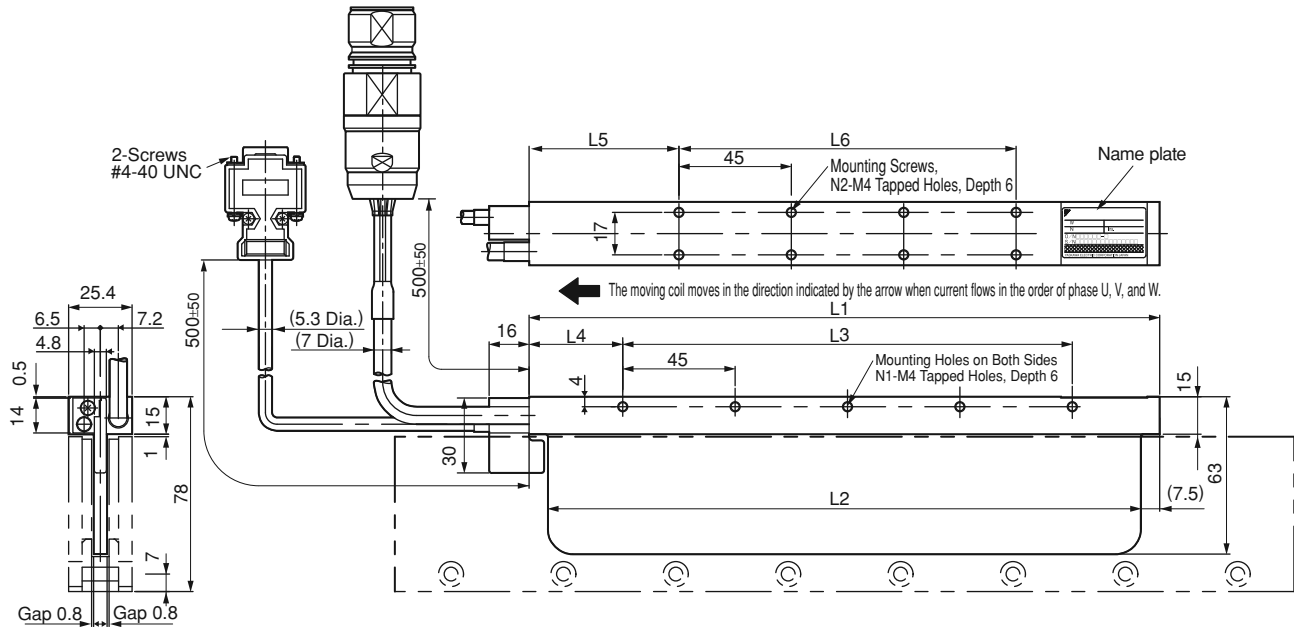

### Hall Sensor Connector Specifications

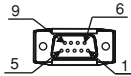

Pin Connector :  
17JE-23090-02 (D8C)  
by DDK Ltd.

The Mating Connector  
Socket Connector :  
17JE-13090-02 (D8C)  
Stud : 17L-002C or  
17L-002C1

Pin No.	Signal
1	+5V (Power supply)
2	Phase U
3	Phase V
4	Phase W
5	0V (Power supply)
6	Not used
7	Not used
8	Not used
9	Not used

### Linear Servomotor Connector Specifications

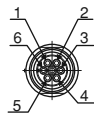

Extension: SROC06JMSCN169  
Pin : 021.423.1020  
by Interconnectron GmbH

The Mating Connector  
Plug : SPUC06KFSDN236  
Socket: 020.030.1020

Pin No.	Signal	Wire Color
1	Phase U	Red
2	Phase V	White
3	Phase W	Blue
4	Not used	-
5	Not used	-
6	FG	Green

### Hall Sensor Output Signals

When the moving coil moves in the direction indicated by the arrow in the figure, the relationship between the hall sensor output signals  $S_u$ ,  $S_v$ ,  $S_w$  and the inverse power of each motor phase  $V_u$ ,  $V_v$ ,  $V_w$  becomes as shown in the figure below.

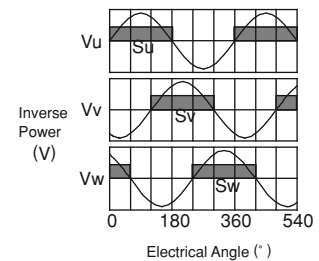

Moving Coil Model SGLGW-	L1	L2	L3	L4	L5	L6	N1	N2	Approx. Mass* kg
40A140C□D	140	125	90	30	52.5	45	3	4	0.40
40A253C□D	252.5	237.5	180	37.5	60	135	5	8	0.66
40A365C□D	365	350	315	30	52.5	270	8	14	0.93

\*: The values indicate the mass of moving coil with a hall sensor unit.

**External Dimensions** Units: mm

- Magnetic Way : SGLGM-40□□□C (Without mounting holes on the bottom)  
SGLGM-40□□□CT (With mounting holes on the bottom)

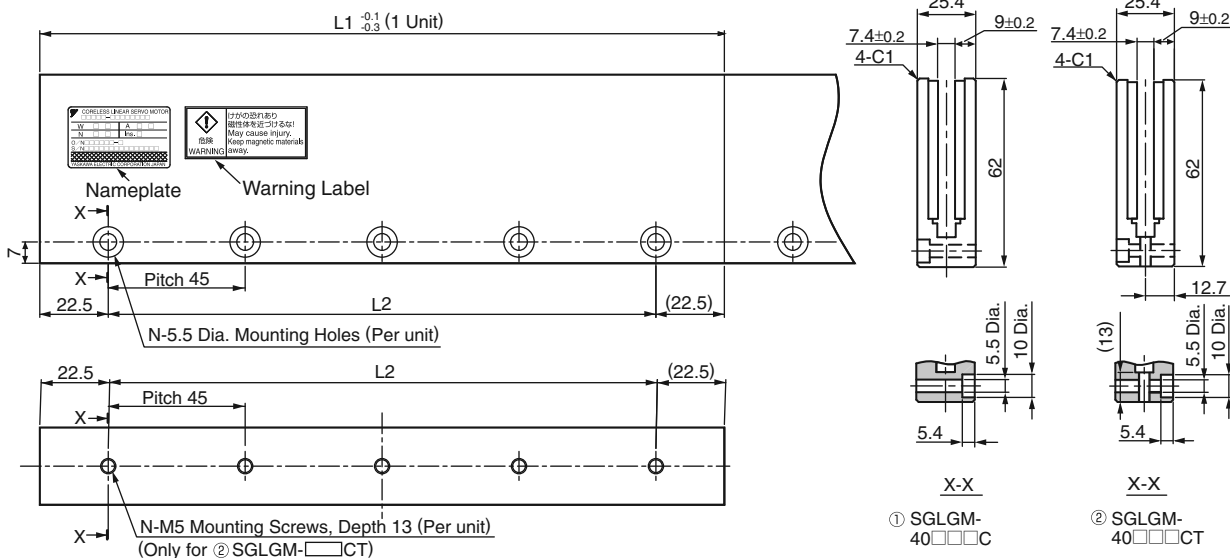

Type	Standard-force Magnetic Way Model SGLGM-	L1	L2	N	Approx. Mass kg
Standard Force	40090C or 40090CT	90	45	2	0.8
	40225C or 40225CT	225	180	5	2.0
	40360C or 40360CT	360	315	8	3.1
	40405C or 40405CT	405	360	9	3.5
	40450C or 40450CT	450	405	10	3.9

Note: If you have a pacemaker or any other electronic medical device, do not go near the magnetic way of the linear servomotor.

- High-force Magnetic Way : SGLGM-40□□□C-M (Without mounting holes on the bottom)  
SGLGM-40□□□CT-M (With mounting holes on the bottom)

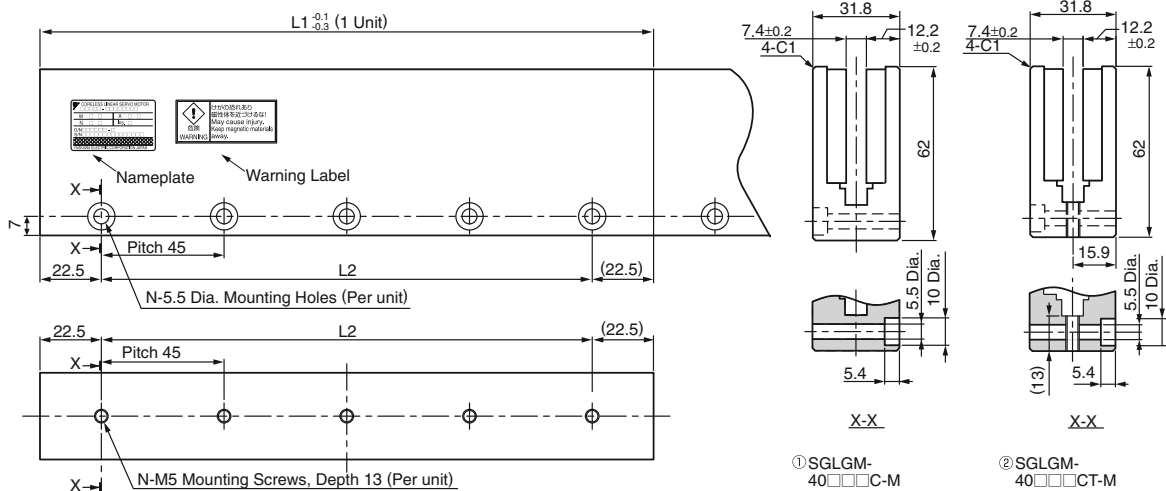

Type	High-force Magnetic Way Model SGLGM-	L1	L2	N	Approx. Mass kg
High Force	40090C-M or 40090CT-M	90	45	2	1.0
	40225C-M or 40225CT-M	225	180	5	2.6
	40360C-M or 40360CT-M	360	315	8	4.1
	40405C-M or 40405CT-M	405	360	9	4.6
	40450C-M or 40450CT-M	450	405	10	5.1

Note: If you have a pacemaker or any other electronic medical device, do not go near the magnetic way of the linear servomotor.

# External Dimensions Units: mm

## (3) SGLGW-60

- Moving Coil: SGLGW-60A□□□C□ (With a connector by Tyco Electronics AMP K.K.)

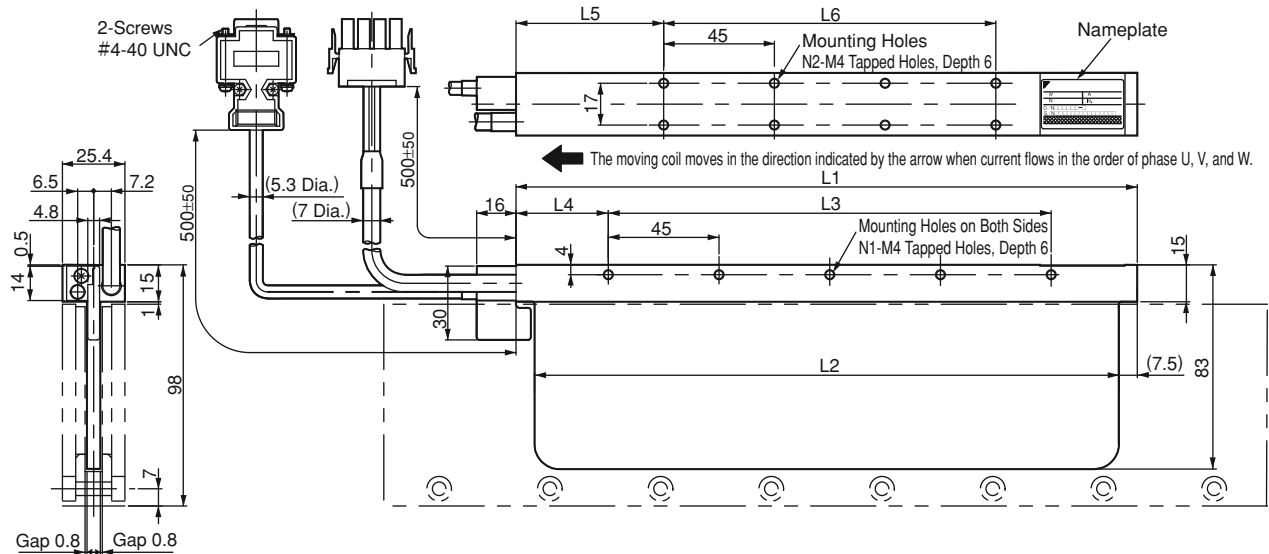

### Hall Sensor Connector Specifications

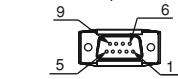

Pin Connector :  
17JE-23090-02 (D8C)  
by DDK Ltd.

The Mating Connector  
Socket Connector :  
17JE-13090-02 (D8C)  
Stud : 17L-002C or  
17L-002C1

Pin No.	Signal
1	+5V (Power supply)
2	Phase U
3	Phase V
4	Phase W
5	0V (Power supply)
6	Not used
7	Not used
8	Not used
9	Not used

### Linear Servomotor Connector Specifications

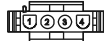

Plug : 350779-1  
Pin : 350561-3 or  
350690-3 (No.1 to 3)  
350654-1  
350669-1 (No.4)  
by Tyco Electronics AMP K.K.

The Mating Connector  
Cap : 350780-1  
Socket : 350570-3 or  
350689-3

Pin No.	Signal	Wire Color
1	Phase U	Red
2	Phase V	White
3	Phase W	Blue
4	FG	Green

### Hall Sensor Output Signals

When the moving coil moves in the direction indicated by the arrow in the figure, the relationship between the hall sensor output signals  $S_u$ ,  $S_v$ ,  $S_w$  and the inverse power of each motor phase  $V_u$ ,  $V_v$ ,  $V_w$  becomes as shown in the figure below.

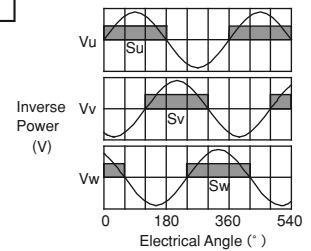

Moving Coil Model SGLGW-	L1	L2	L3	L4	L5	L6	N1	N2	Approx. Mass* kg
60A140C□	140	125	90	30	52.5	45	3	4	0.48
60A253C□	252.5	237.5	180	37.5	60	135	5	8	0.82
60A365C□	365	350	315	30	52.5	270	8	14	1.16

\*: The values indicate the mass of moving coil with a hall sensor unit.

**External Dimensions** Units: mm

- Moving Coil: SGLGW-60A□□□C□D (With a connector by Interconnectron GmbH)

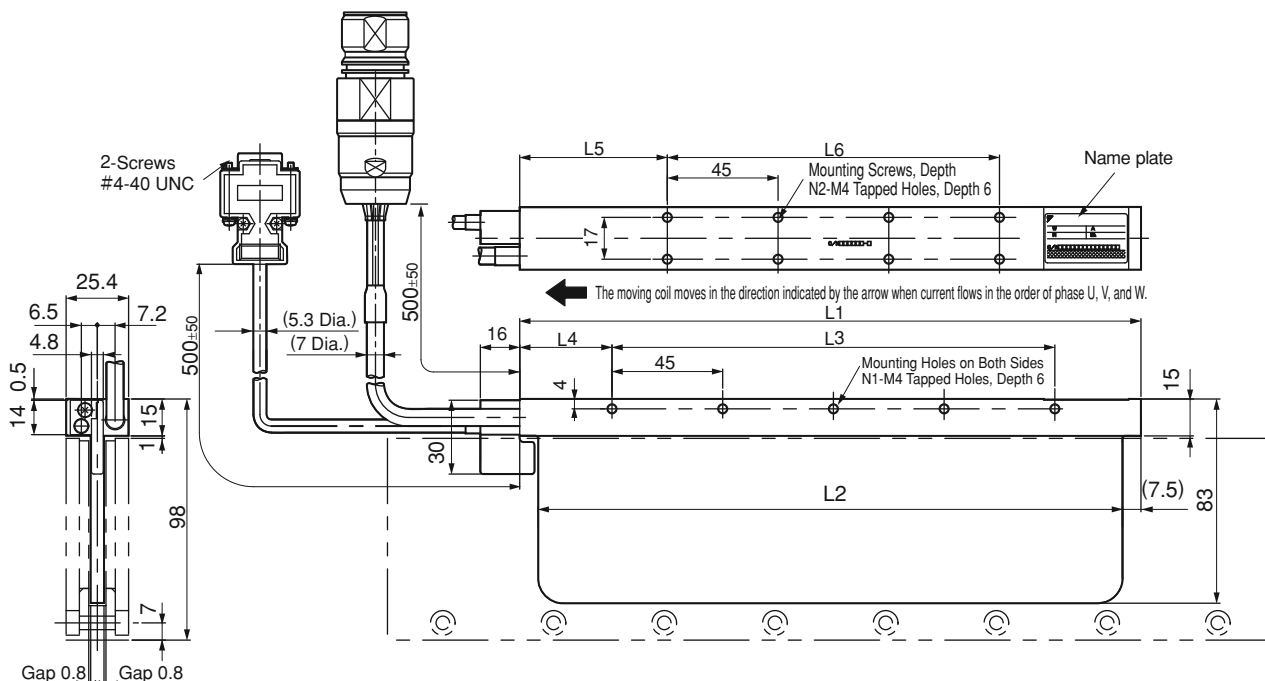

Hall Sensor Connector Specifications

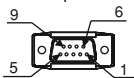

Pin Connector :  
17JE-23090-02 (D8C)  
by DDK Ltd.

The Mating Connector  
Socket Connector :  
17JE-13090-02 (D8C)  
Stud : 17L-002C or  
17L-002C1

Pin No.	Signal
1	+5V (Power supply)
2	Phase U
3	Phase V
4	Phase W
5	0V (Power supply)
6	Not used
7	Not used
8	Not used
9	Not used

Linear Servomotor Connector Specifications

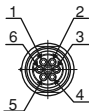

Extension: SROC06JM5CN169  
Pin : 021.423.1020  
by Interconnectron GmbH

The Mating Connector  
Plug : SPUC06KFSDN236  
Socket: 020.030.1020

Pin No.	Signal	Wire Color
1	Phase U	Red
2	Phase V	White
3	Phase W	Blue
4	Not used	-
5	Not used	-
6	FG	Green

Hall Sensor Output Signals

When the moving coil moves in the direction indicated by the arrow in the figure, the relationship between the hall sensor output signals  $S_u$ ,  $S_v$ ,  $S_w$  and the inverse power of each motor phase  $V_u$ ,  $V_v$ ,  $V_w$  becomes as shown in the figure below.

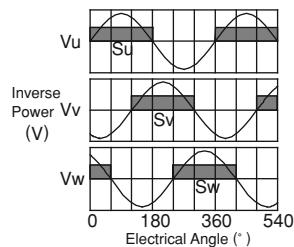

Moving Coil Model SGLGW-	L1	L2	L3	L4	L5	L6	N1	N2	Approx. Mass* kg
60A140C□D	140	125	90	30	52.5	45	3	4	0.48
60A253C□D	252.5	237.5	180	37.5	60	135	5	8	0.82
60A365C□D	365	350	315	30	52.5	270	8	14	1.16

\*: The values indicate the mass of moving coil with a hall sensor unit.

## External Dimensions Units: mm

- Magnetic Way : SGLGM-60□□□C (Without mounting holes on the bottom)  
SGLGM-60□□□CT (With mounting holes on the bottom)

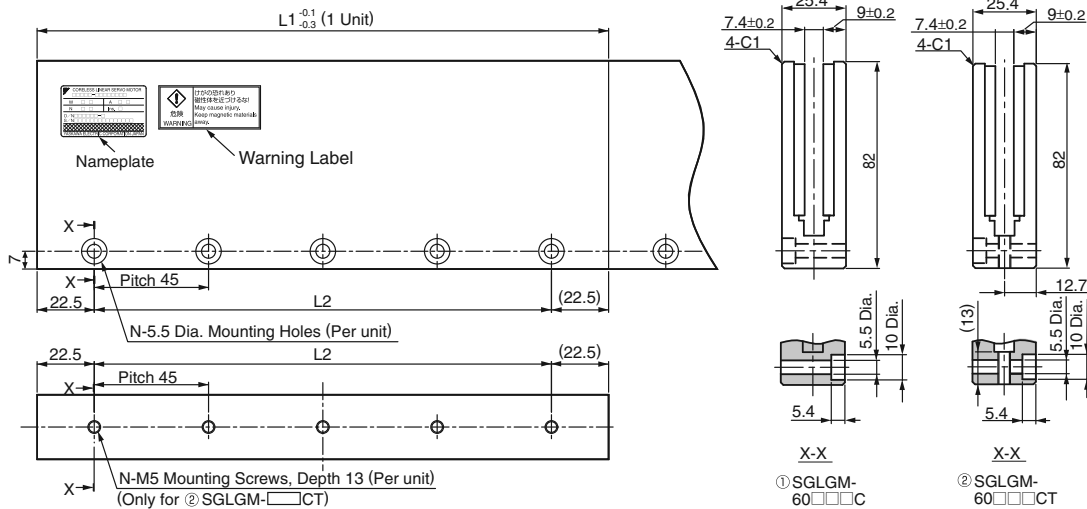

Type	Standard-force Magnetic Way Model SGLGM-	L1	L2	N	Approx. Mass kg
Standard Force	60090C or 60090CT	90	45	2	1.1
	60225C or 60225CT	225	180	5	2.6
	60360C or 60360CT	360	315	8	4.1
	60405C or 60405CT	405	360	9	4.6
	60450C or 60450CT	450	405	10	5.1

Note: If you have a pacemaker or any other electronic medical device, do not go near the magnetic way of the linear servomotor.

- High-force Magnetic Way : SGLGM-60□□□C-M (Without mounting holes on the bottom)  
SGLGM-60□□□CT-M (With mounting holes on the bottom)

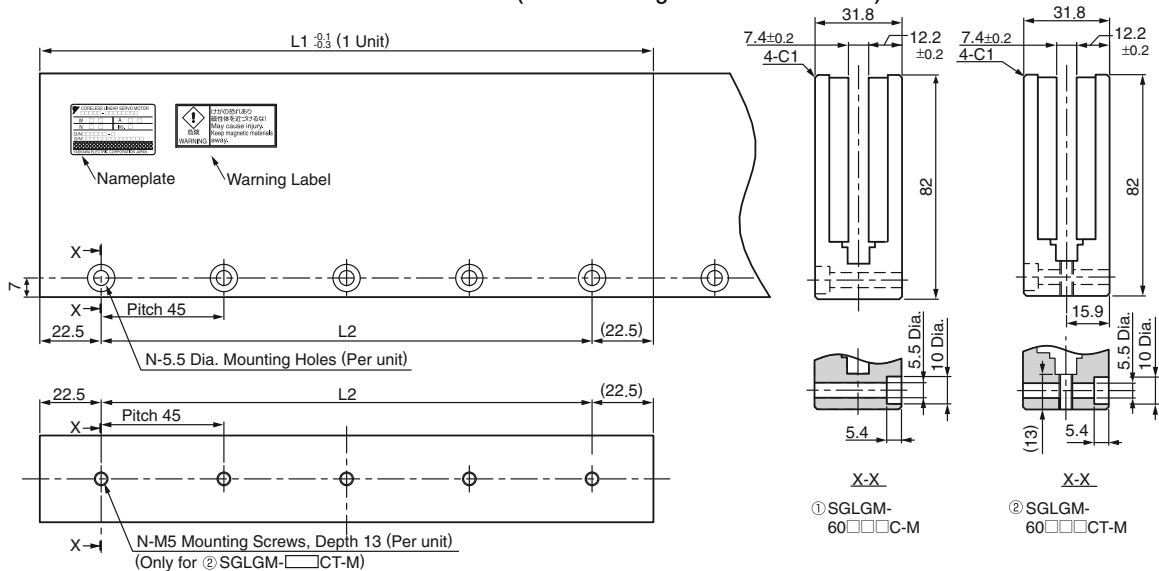

Type	High-force Magnetic Way Model SGLGM-	L1	L2	N	Approx. Mass kg
High Force	60090C-M or 60090CT-M	90	45	2	1.3
	60225C-M or 60225CT-M	225	180	5	3.3
	60360C-M or 60360CT-M	360	315	8	5.2
	60405C-M or 60405CT-M	405	360	9	5.9
	60450C-M or 60450CT-M	450	405	10	6.6

Note: If you have a pacemaker or any other electronic medical device, do not go near the magnetic way of the linear servomotor.

**External Dimensions** Units: mm

(4) SGLGW-90

- Moving Coil: SGLGW-90A□□□C□ (With a connector by Tyco Electronics AMP K.K.)

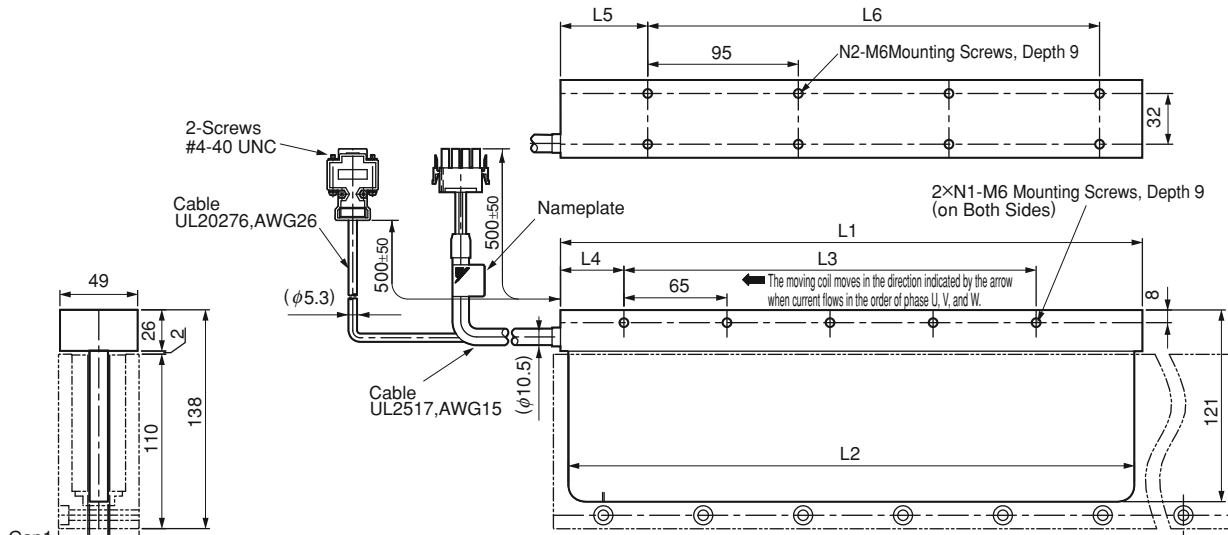

**Hall Sensor Connector Specifications**

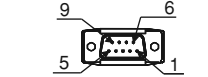

Pin Connector :  
17JE-23090-02 (D8C)  
by DDK Ltd.

The Mating Connector  
Socket Connector :  
17JE-13090-02 (D8C)  
Stud : 17L-002C or  
17L-002C1

Pin No.	Signal
1	+5V (Power supply)
2	Phase U
3	Phase V
4	Phase W
5	0V (Power supply)
6	Not used
7	Not used
8	Not used
9	Not used

**Linear Servomotor Connector Specifications**

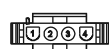

Plug : 350779-1  
Pin : 350218-3 or  
350547-3 (No.1 or 3)  
350654-1  
350669-1 (No.4)  
by Tyco Electronics AMP K.K.

The Mating Connector  
Cap : 350780-1  
Socket : 350536-3 or  
350550-3

Pin No.	Signal	Wire Color
1	Phase U	Red
2	Phase V	White
3	Phase W	Blue
4	FG	Green

**Hall Sensor Output Signals**

When the moving coil moves in the direction indicated by the arrow in the figure, the relationship between the hall sensor output signals Su, Sv, Sw and the inverse power of each motor phase Vu, Vv, Vw becomes as shown in the figure below.

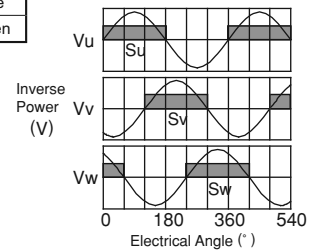

Moving Coil Model SGLGW-	L1	L2	L3	L4	L5	L6	N1	N2	Approx. Mass* kg
90A200C□	199	189	130	40	60	95	3	4	2.2
90A370C□	367	357	260	40	55	285	5	8	3.65
90A535C□	535	525	455	40	60	380	8	10	4.95

\*: The values indicate the mass of moving coil with a hall sensor unit.

External Dimensions Units: mm

- Magnetic Way: SGLGM-90□□□A

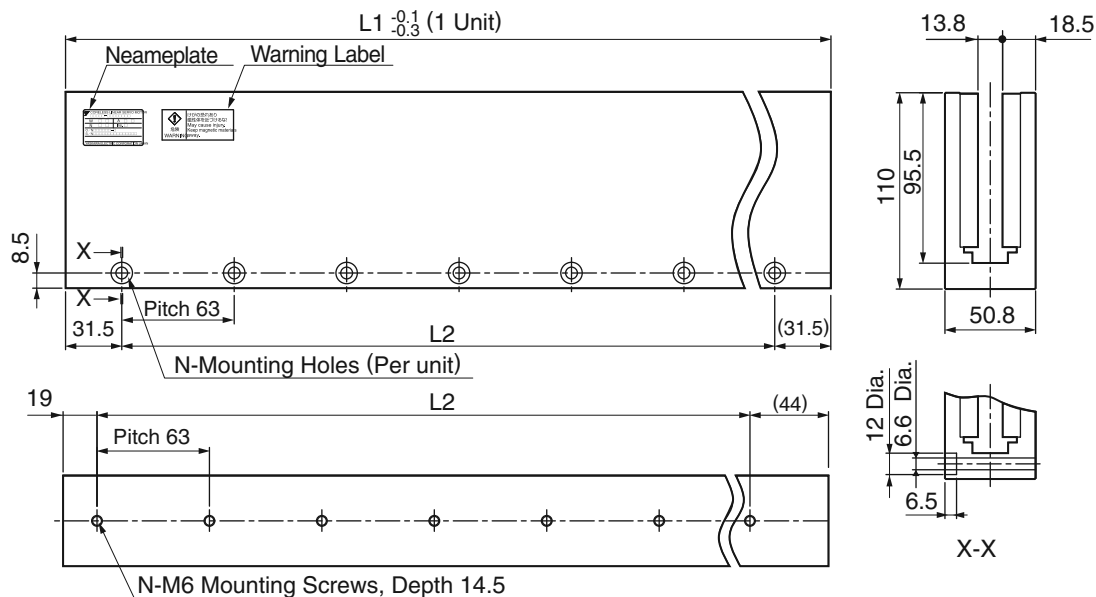

Magnetic Way SGLGM-	L1	L2	N	Approx. Mass kg
90252A	252	189	4	7.3
90504A	504	441	8	14.7

Note: If you have a pacemaker or any other electronic medical device, do not go near the magnetic way of the linear servomotor.